

LITHIUM

LiFePO4

LITHIUM (LiFePO4) | High Performance

REF **BSLi-10**



12_v

VOLTAGE

72_{Wh}

ENERGY

360_A

CCA

TECHNOLOGY

- Lithium Iron Phosphate cells construction
- Pre-charged batteries
- Homologated by OEM

FEATURES

- Fast charging
- Multi-positioning mounting
- Very safe and environmental friendly
- Extensive cycle life: over 2000 cycles
- Very low self-discharge
- Cold temperature performance
- Waterproof design
- Ready to use: just plug and play
- Robust brass terminals
- Heat resistance: up to 230 C°
- Lighter weight

REPLACEMENTS

BTX20L	BTX20L-BS	B50-N18L-A
BTX20HL	BTX20HL-BS	B50-N18L-A2/A3/AT
BTX24HL	BTX24HL-BS	

MOUNTING ANGLE

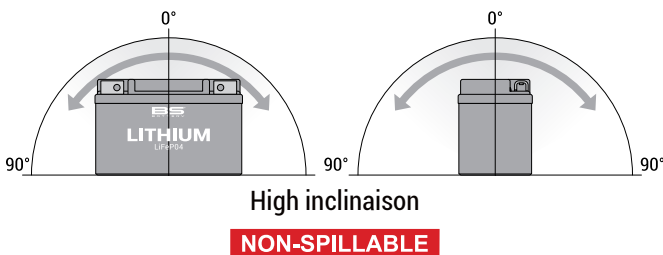

DIMENSIONS & WEIGHT

Length (L): 148±1mm
 Width (W): 86±1mm
 Height (H): 105±2mm
 Weight: 1.28kg (tolerance ±3%)

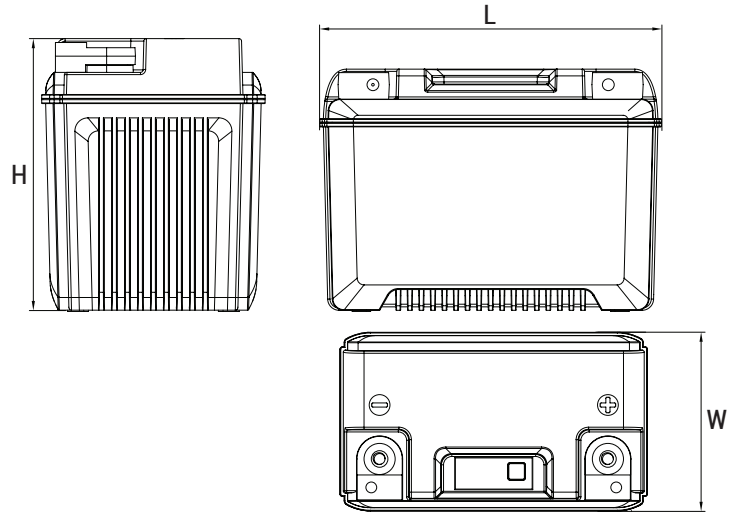

TERMINALS

